

DAWN / CARVER BAR CLAMPS

These rugged clamps, has the same features and benefits of the rack clamps and are designed for all types of applications requiring large holding capacities and jaw width. Highly versatile - jaws can be reversed to provide spreading action, or several jaws can be used on a single bar both for fixturing and positive component location and clamping. In addition, standard and medium-duty connectors are available to couple like bars together for increased clamping reaches.

	Model No.	Part No.	Clamping Force (daN)	Jaw Opening (mm)	Throat Depth (mm)	Overall Length (mm)	Weight (kg)
Standard Duty	T186 - 600	301179	1130	600	60	710	3.4
	T186 - 900	301180	1130	900	60	1020	4.4
	T186 - 1500	301182	1130	1500	60	1625	5.8
	T186 - 2100	301184	1130	2100	60	2235	7.6
	T186 - 2400	301185	1130	2400	60	2540	8.8
Standard Duty Long Reach	T321 - 600	301187	565	600	120	710	3.5
	T321 - 900	301188	565	900	120	1020	4.5
	T321 - 1500	301190	565	1500	120	1625	5.9
	T321 - 2100	301192	565	2100	120	2235	7.7
	T321 - 2400	301193	565	2400	120	2540	8.9
Medium Duty	T290 - 900	301195	1800	900	90	1070	10.5
	T290 - 1200	301196	1800	1200	90	1390	12.1
	T290 - 1500	301197	1800	1500	90	1690	14.0
	T290 - 2100	301199	1800	2100	90	2290	18.0
Medium Duty Long Reach	T285 - 900	301203	900	900	200	1070	11.5
	T285 - 1200	301204	900	1200	200	1390	13.0
	T285 - 1500	301205	900	1500	200	1690	15.0
	T285 - 2100	301207	900	2100	200	2290	19.0
Heavy Duty	T257 - 2100	301210	2700	2100	115	2335	27.2
	T257 - 2700	301212	2700	2700	115	2945	32.0

Alternative uses of Bar Clamps

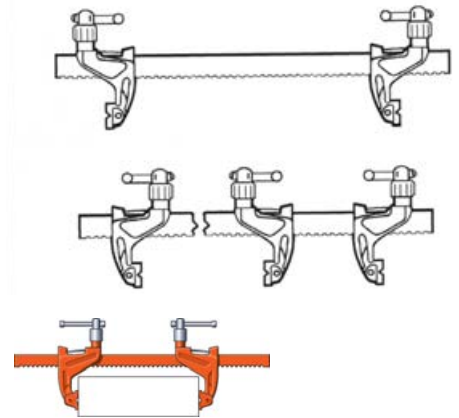

Optional Extras: T186 Connector for Standard Duty & T285 Connector for Medium Duty Clamps

